

30GL

Basic model with a clear view to the retina
for accurate diagnosis

- Design optimized for everyday clinical environments
- Stereoscopic field of view of Greenough optics
- Intuitive and smooth operations



Serving Your Vision

TAKAGI ophthalmic devices, proudly made in Japan since 1955.

Designed for everyday clinical use, offering an ideal balance of user-friendliness and essential functionality. The clear and detailed images help the early discovery of disease and appropriate treatment.



Efficient examination environment, friendly to both doctors and patients

To reduce the burden on doctors during long examinations and minimize fatigue, the design focuses on ease of use, from the size and positioning of the operating parts to their operational feel. The simple optical structure results in intuitive operations. 30GL is ideal for facilities that prioritize cost-effectiveness. This model uses an energy-saving LED light source which provides stable brightness over a long service life. This allows a design with built-in cables and reduces heat generation, contributing to enhanced patient safety.



Greenough optics provide a bright and clear view with enhanced depth perception

The 30GL is equipped with a Greenough microscope which provides rich stereoscopic images that are easy to fuse, helping to accurately identify the condition of affected areas. Combined with a high-luminance LED light source, it ensures a bright and clear view.

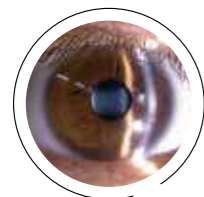

Filter not in use

Since the intrinsic blue light of LED is rich, the light scattering makes areas such as the cornea, aqueous humor, lens, and vitreous humor clearly visible.

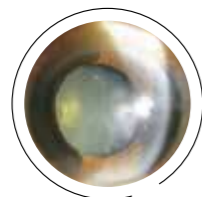

Blue correction filter in use

The blue light characteristic of LEDs is reduced to make the light easier on the eye. Its natural color tone, resembling that of a halogen lamp, reduces eye strain and delivers a well-balanced observation image.



Blue cut filter in use

Retina strain is reduced by restricting light scattering and delivering the light as far as the fundus, while minimizing the effects of blue light.

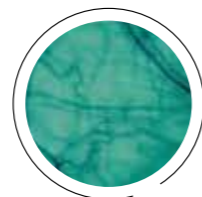

Green filter in use

Since red blood vessels and bleeding are shown in black, the contours of tiny lesions are highlighted to provide clear observation images in fine detail.

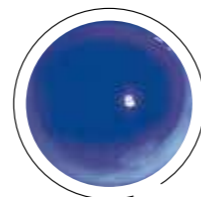

Blue filter in use

When combined with fluorescein staining, this model is effective not only for ocular tonometry, but also to clarify the condition of the cornea and tear fluid, and conduct fitting checks for contact lenses.



KEY POINT

The design consists of parts such as a large-diameter dimmer knob arranged functionally around the joystick for easy operation with one hand.



KEY POINT

The size and feel of the large-diameter control knob are optimally designed for comfortable operation.



KEY POINT

The front lens can be held in a stable position using the finger rest of the forehead rest. This makes observations easier and reduces the burden on the doctor's arms, while also minimizing contact with patients.

Basic model for stable performance

An environmentally friendly, long-life LED is adopted. This eliminates the need for frequent light source replacement, reducing maintenance work and saving natural resources.

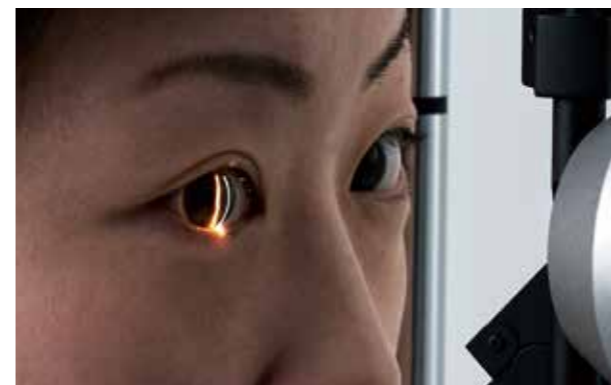

Learn more

Specifications

| | | |
|--|-----------------------|--|
| Model name | | 30GL Slit Lamp Microscope |
| Microscope | Type | Greenough binocular stereo microscope |
| | Magnification changer | Revolver objective changing system with 2 magnification changes |
| | Eyepiece | 10x, 16x |
| | Total magnifications | 10x / 16x (When 10x eyepieces are in use) 16x / 25x (When 16x eyepieces are in use) |
| Illumination Unit | Slit image width | Continuously variable 0-14 mm (almost circular at 14 mm) |
| | Slit image length | Continuously variable 1-14 mm |
| | Filters | Blue / Green (red-free) / Blue correction / Blue cut |
| | Light source | LED (3500K) |
| Power Unit | Power supply | AC 100-240 V (±10%), 0.4-0.2 A |
| | Power input | DC 5 V 2 A |
| Weight (excl. power adapter & options) | | 12.5 kg |

Dimensions

Dimensions (mm)

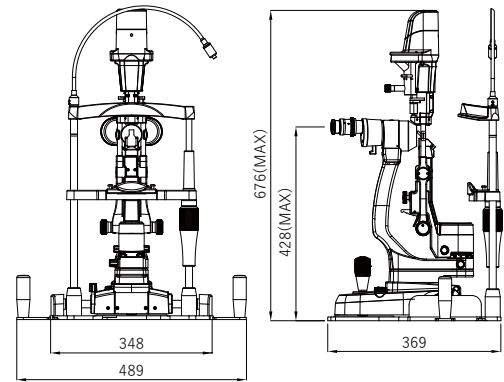

Flexible customization with a rich variety of options



Accessories

| | | | |
|---|--------|-----------------------|---|
| 1 | AT-1 | Applanation Tonometer | Supports a wide range of slit lamps made by TAKAGI |
| 2 | TB30 | Tonometer Base | For AT-1 attachment |
| 3 | S06-68 | Diffuser | Diffuses illumination, effective for observing the entire eye and surrounding areas |

 To ensure safe and correct handling please read the user manual before using.

- Description and appearance as detailed in this brochure may be subject to change as improvements are made to products.
- Colors of product(s) in brochure may slightly differ from actual product(s) due to lighting situation when photographed or print conditions.

For The Americas, Asia-Pacific & Middle East

Takagi Seiko Co., Ltd.

330-2 Iwafune, Nakano-shi, Nagano-ken, 383-8585, Japan
TEL : +81(0)269-22-6094 URL : <https://www.takagi-j.com>



Your local distributor

For Europe & Africa

Takagi Ophthalmic Instruments Europe Ltd.

Citylabs 1.0, Nelson Street, Manchester, M13 9NQ, UK
TEL : +44 (0)161 273 6330 URL : <https://www.takagi-europe.com>